



OPERATOR'S GUIDE

ElmaTear

Intelligent Digital
Tear Tester

TestWise Data Logger

Covering serial numbers
1555/15/1001 & upwards

Published by:

JAMES HEAL
RICHMOND WORKS
HALIFAX
WEST YORKSHIRE
HX3 6EP
ENGLAND

TELEPHONE +44 (0) 1422 366355
FACSIMILE +44 (0) 1422 352440

E-mail info@james-heal.co.uk
Internet <http://www.james-heal.co.uk>

© 2017

TABLE OF CONTENTS

JAMES HEAL	5
Setting the Standard	5
Areas of Expertise	5
ElmaTear Digital Tear Tester	6
Features & Benefits	6
Features of ElmaTear	7
Summary of Test Procedure	8
Scope of Application	9
Standards	9
Installation	10
Safety.....	10
Unpacking.....	10
Checklist	11
Standard Accessories	11
Optional Accessories.....	13
Spares.....	13
Securing to Work Surface.....	13
Levelling	14
Electrical Connection	14
Preparing for Use	14
Operation	15
Operator Safety	15
ElmaTear Pendulum Weights & Check Weights.....	16
Pendulum Weights.....	17
Pendulum Weights - Units of Measurement	17
Pendulum Verification.....	18
Check Weights.....	19
Check Weights - Acceptable Parameters	20
Changing the Jaw Faces	21
Cutting Blade.....	22
Replacing the Blade	22
Setting the Cut Length	23
Testing the Specimen	24
Using The Touchscreen	25
Main Menu	25
Standard Settings.....	26
Test Page	27
Report Page.....	28

TestWise for ElmaTear.....	29
Hardware Connections.....	29
Software Installation.....	29
Using TestWise for ElmaTear.....	30
Care and Maintenance.....	33
Touch Screen Care.....	33
James Heal Service & Calibration.....	33
Technical Data.....	34
EU Conformity.....	36
Revision History.....	37

JAMES HEAL

At James Heal, we are dedicated to designing and developing high precision testing instruments and test materials for physical and colour fastness testing. Our worldwide Service and Calibration division and expert technical assistance complement our product range, adding real value to your laboratory testing activities.

Setting the Standard

We are committed to forming close relationships and have established numerous partnerships within the textile industry, from trade and standards organizations, to test houses, customers and distribution partners.

With a heritage spanning more than 140 years, we have evolved and grown through a culture of continuous improvement, resulting in a thorough understanding of the applications, operating conditions and requirements of customers worldwide - from independent testing Laboratories and test houses, to fabric suppliers, manufacturers and retailers.

Using knowledge and expertise, we consistently set the industry standard through product innovation and technology, with customer and user needs, present and future, driving our technological advancements. You can be assured that with James Heal, you will always receive the highest levels of product quality and customer service. We have Agents and Distribution partners all over the globe, ensuring locally available product whenever, and wherever you need it.

Areas of Expertise

Textile: Colour Fastness

- Chlorinated Water
- Dry Cleaning
- Dry Heat
- Hot Pressing
- Laundering
- Light
- Perspiration
- Phenolic Yellowing
- Print Durability
- Rubbing
- Washing
- Water

Textile: Physical

- Abrasion
- Bursting Strength
- Compression and Puncture
- Crease and Wrinkle Recovery
- Crimp
- Drape
- Durability
- Flammability
- Mass per unit area
- Pilling and Fuzzing
- Security of Attachments
- Seam Slippage
- Shrinkage
- Snagging
- Spray Rating
- Stretch and Recovery
- Surface Deterioration
- Tear Strength
- Tensile Strength
- Washing and Drying

Non-Textile

- Bursting strength of nonwovens, plastics, paper and medical products
- Micro-scratching of laminates, wooden, painted, automotive and high gloss surfaces
- Physical and colour fastness testing of leather
- Rubbing fastness of laminates and wooden surfaces
- Tear strength of paper and plastics

ELMATEAR DIGITAL TEAR TESTER

ElmaTear has been designed with James Heal's unique product signature and has been produced completely with the user in mind. We have combined James Heal's technical and performance expertise, with intuitive design and operation to produce the most ergonomic and user friendly instrument.

As standard, the instrument capacity is 64N, the optional E-Pendulum Kit doubles the capacity to 128N. Compared with the traditional Elmendorf Tear Tester, the testing routine is simplified and accelerated. The operator selects the unit of measurement and the number of plies - the test result is displayed digitally - no calculations, conversion factors or look-up tables are required. All calculations, including statistics, are carried out by the instrument and displayed on the screen.

Features & Benefits

- Light weight pendulums 2N & 4N ($\frac{1}{2}A$ & $\frac{1}{4}A$)
- Capacity up to 128N
- 7" Capacitive colour TFT touchscreen
- Sleek, ergonomic design
- Single swing calibration
- Long-life titanium nitride coated blade
- Specimen notch detection
- Auto adjust jaws
- Units of measurement: N, cN, mN, kgf, gf, lbf, ozf
- Supplied with calibration check weights and specimen templates
- PC Software Package - TestWise Data Logger Software
- 18 months warranty
- Engineering Support
- Applications Support
- Operator training is available through James Heal

Features of ElmaTear



Summary of Test Procedure

The mean force required to propagate a single tear in a material is determined by measuring the work done in tearing it through a fixed distance of 86mm (twice the tearing length of 43mm). **ElmaTear** consists of a V-shaped pendulum arm carrying a clamp which is aligned with a fixed clamp when the pendulum arm is in the raised starting position with maximum potential energy.

ElmaTear employs the energy conversion principle, i.e., potential energy converted to kinetic energy, to determine the work done. The potential energy is stored in the pendulum by raising its centre of gravity to a known distance above its neutral point. The work done on the test specimen is the difference between the original potential energy and the sum of remaining kinetic and potential energies at the completion of the tear. This sum determines the amplitude of the pendulum arm swing. All air resistance and friction losses are compensated for through calibration and thus this amplitude is used to calculate the work done. The tearing force is calculated by dividing the work done by twice the tear length ($2 \times 43\text{mm}$).

The test specimen is fastened in the clamps and the tear is started by pre-cutting / notching the specimen between the two clamps. The pendulum arm is then released and the specimen is torn as the moving jaw moves away from the fixed jaw.

The difference in the angle from the vertical of the centre of gravity of the pendulum between the downswing and the upswing is a measure of the energy absorbed in tearing the sample. This angular movement is measured using a digital encoder and converted to the mean tearing force by the microprocessor in the apparatus.

The digital display shows the tearing force in the chosen units.

The mode of tearing is more or less as shown in the figures below, but the relative angle of pull changes continuously during the test. This means that the mode of failure is a continuously changing combination of in and out of plane tensile and shear.

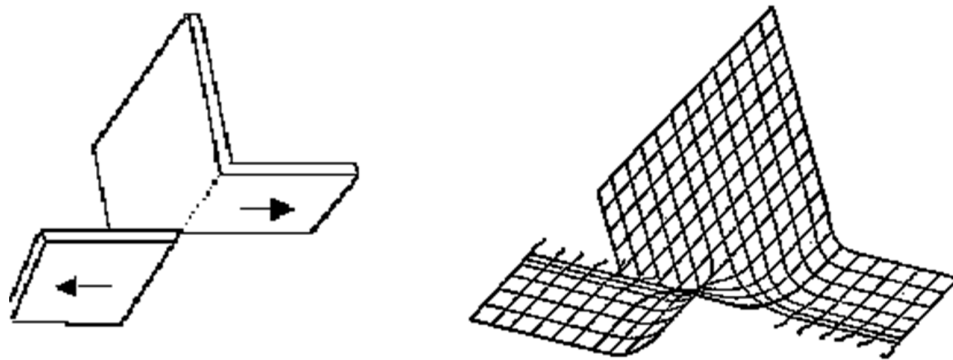

Scope of Application

The test procedure is applicable to woven fabrics, coated fabrics, foils, paper, board, plastic films, nonwoven fabrics, laminates and other sheet materials. It is not applicable to knitted textile fabrics or isotropic materials such as felts.

Standards

Textile	Paper	Nonwoven	Plastics
ASTM D 1424 GB/T 3917.1 EN ISO 13937-1 ISO 4674-2 M&S P29 NEXT 17 AS 2001.2.8 BIS IS 6489-1 CAN/CGSB 4.2 No.12.3 JIS L 1096 D	GB/T 455 ISO 1974 PAPTAC D9 TAPPI T414 AS/NZS 1301.400s	WSP 100.1	ASTM D 1922 ISO 6383-2 JIS K 7128-2 BIS IS 13360-5-23 GB/T 16578.2

INSTALLATION

Safety

ElmaTear has a mass of approximately 50Kg, therefore assistance from a colleague and suitable lifting apparatus is recommended. **ElmaTear** is delivered on a wooden palette. Use a forklift truck or hydraulic pump trolley to move the packing case as near as possible to the final location. **ElmaTear** can now be lifted from its palette and into location using a pump truck if available. If lifting by hand a minimum of 3 people will be required.

Once in position, follow the instructions in the *Unpacking* section below to remove the outer case.

Before removing any covers, ensure the instrument is isolated from the electrical supply; these should only be removed by a qualified engineer or electrician.

Have the instrument serviced and calibrated at least once a year by a James Heal Service and Calibration Engineer.

Read this manual carefully before operating the instrument and refer to Operator Safety.

Unpacking

Remove the tape from the packing case lid and open. Carefully remove the packaging and contents from the packing case. Note that any accessories ordered with the instrument are packed with the instrument.

Remove the sleeve and then very carefully lift the instrument by the base and place it on a firm flat surface. **It is imperative that the surface is stable and level as the instrument will lose energy with any movement.**

Do not dispose of any packaging material until all standard and optional accessories ordered are fully accounted for. If there are any discrepancies, please contact your supplier immediately.

Checklist

Standard Accessories

Please check the serial number plate to confirm that the supply voltage and frequency are in accordance with your order. Also, check the items listed in the tables below are present:

Item number	Item name	Quantity
903-305	ElmaTear Digital Tear Tester Model 1555	1
201-1555	ISO Certificate for ElmaTear 1555	1
299-001	Universal Installation Guide	1
142-304	Mains lead set (straight)	1
195-411	*Circular Snap-On Ferrite Core 14.5mm	1
154-184	USB lead (2m type A to type B)	1
761-801	Cutting Boards (grey) - one board only	1
130-825	Fuse 1A T 20x5mm	1
528-988	**Threaded stud - long	2
319-117	**M10 SS Nuts	2
319-116	**M10 SS Washers	2
529-762	Metal Jaw Separator plate	1
794-995	PC Software TestWise Data Logger Software	1
*To maintain EMC Compliance, this item should be attached to the required mains electrical cable.		
**These 3 items are used to secure ElmaTear to a solid bench surface - sometimes required when using Pendulum E. Typically, securing to a bench is not required.		

Item number	Item name	Quantity
794-778	Standard Accessories Kit for ElmaTear 1555	1
	containing	
381-108	17 mm A/F Spanner	1
381-109	5mm hexagon key	1
381-411	2mm hexagon key	1
381-427	Slotted screwdriver 0.8 x 4	1
399-138	Knife blade box with foam	1
761-818	ElmaTear blade (spare)(boxed in 399-138)	1
528-595	Blade setting block (15mm and 20mm)	1
529-708	¼A Pendulum	1
529-709	½A Pendulum	1
529-710	A Pendulum	1
529-711	B Pendulum	1
529-712	C Pendulum	1
529-713	D Pendulum	2
529-715	¼A Check Weight	1
529-716	½A Check Weight	1
528-910	A Check Weight	1
528-911	B Check Weight	1
529-717	C Check Weight	1
529-718	D Check Weight	1
529-758	Prop Pin - Red (used for supporting Pendulum Arm while replacing the cutting blade)	1
772-108	Template 100 x 63 mm - ISO 9290 Method B	1
772-109	Template 100 x 63 mm (Shaped)	1
772-117	Template ASTM D1424	1
772-118	Template ISO 13937-1	1
772-122	Template - 78mm x 63mm (paper)	1
772-284	Template - ISO 6383-2	1
772-286	Template - ASTM D1922 (plastic films)	1

Optional Accessories

Item number	Item name	Quantity
794-777	E-Pendulum Kit for model 1555	1
	containing	
529-714	E Pendulum (in 4 parts)	4
529-010	Serrated Jaw (male)	2
529-011	Serrated Jaw (female)	2
529-719	E Check Weight	1

Spare Parts List

Item number	Item name	Quantity
761-818	Blade	1
794-738	Wheel Block Set	1
375-514	Torsion Spring	1
794-737	Plain Jaw Inserts	Set of 4
130-825	Fuse 1A 20mm - anti surge	1
160-462	Electromagnetic brake assembly	1
390-237	Shot-bolt assembly	1

Securing to Work Surface

Due to the unique rapid arresting mechanism it is not necessary to fix the instrument to the work surface. However, when testing using Pendulum E, the instrument may move.

If the instrument moves the results will not be correct as energy will be lost. In this case, we recommend the instrument is firmly secured to a sturdy workbench.

Two holes are provided for this purpose. The bolts and wing-nuts are also supplied with the instrument for securing. The distance between the holes is 460mm (centre to centre) and the required hole size is 9mm. Recheck the level of the instrument after fixing to a work surface and correct if required.

Levelling



The levelling procedure is twofold:

Firstly, level the instrument widthways. To do this, loosen the 17mm hexagon nuts on the front handwheels using the spanner supplied and adjust the height by rotating the handwheels until the levelling bubble is central. Re-tighten the locking nuts.

Secondly, level the instrument lengthways using the back handwheels as above, until the levelling bubble is fully centralised within the black circle.

When using a different pendulum, it is advisable to check the level and repeat the above procedure if required. As a matter of routine, we advise the instrument level is checked at least weekly.

Electrical Connection

A single phase 85-264VAC, 50/60Hz supply is required. The instrument is rated at 60W. A 1.0 amp, 20mm anti-surge fuse is fitted. The instrument is supplied with a mains lead which connects into the left side.

Preparing for Use

The V shaped pendulum arm is secured by 2 pegs above, and a red transit screw below. Before use, remove the transit screw using an allen key, or the arm will not be able to swing freely. The 2 uppermost pegs remain in place.

Remove
the
transit
screw
before
using
ElmaTear

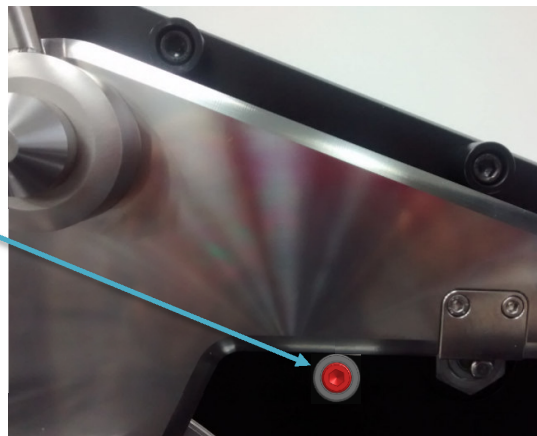

Once this is complete, [ElmaTear](#) is ready for use.

OPERATION

Operator Safety

- Read this manual thoroughly before operating the instrument.
- **Exercise extreme caution when handling the blade - it is very sharp!!**
- When releasing the pendulum, **do not** lean forward into the instrument.
- The path of the swinging pendulum arm is shown by the blue arrow in the figure below.



- Do not store the pendulum weights or any other items on the instrument base.
- Do not attempt to unload the specimen until the pendulum arm has come to rest.
- Only change the pendulum weight when the pendulum arm is in the raised position.
- When notching/pre-cutting a specimen, ensure your free hand and fingers are clear of the blade.
- Some standards contain methods for wet testing. [ElmaTear](#) is not recommended for use with saturated samples, but can be used for samples where the excess has been blotted.

ElmaTear Pendulum Weights & Check Weights

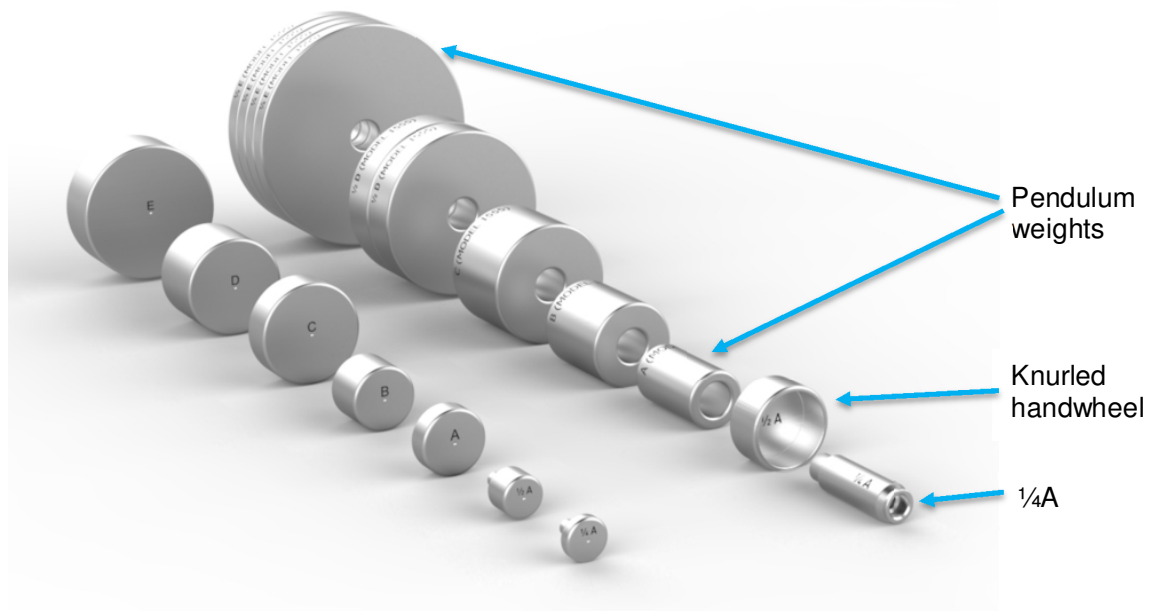

Pendulum Weights

ElmaTear is supplied with a set of six (or seven*) pendulum weights: ¼A, ½A, A, B, C and D (and E*).

The ¼A pendulum is laser marked & permanently attached to the V-shaped pendulum arm.

When the knurled handwheel is attached by screwing into the side of the ¼A pendulum, the instrument has the capacity of ½A.

To further increase the capacity of the instrument, add a pendulum weight to the ¼A pendulum, then secure by using the knurled handwheel. This must be fitted at all times, except when using ¼A pendulum and must be sufficiently tight to prevent the weights from rotating. If the weights are able to rotate during operation the results will be invalid.

Pendulums A, B and C are single weights.

Pendulum D is comprised of two identical, manageable weights.

The optional Pendulum E is comprised of four identical, manageable weights.

Do not store pendulum weights or any other items on the instrument base.

Note: Pendulums marked **Model 1555** cannot be used with previous models of James Heal ElmaTear.

Pendulum Weights - Units of Measurement

Pendulum Weight	N	cN	mN	kgf	gf	lbf	ozf
0.25A	2	200	2000	0.20	204	0.4	7
0.5A	4	400	4000	0.41	408	0.9	14
A	8	800	8000	0.82	816	1.8	29
B	16	1600	16000	1.63	1632	3.6	58
C	32	3200	32000	3.26	3263	7.2	115
D	64	6400	64000	6.53	6526	14.4	230
E*	128	12800	128000	13.05	13052	28.8	460

* Optional

Pendulum Verification

After changing a pendulum weight, the pendulum must be verified before use. With only one swing of the pendulum arm, the instrument will detect which pendulum weight is fitted and zero the instrument.

This is also known as the free swing test which previously required 36 swings to complete.



Touch 'OK' when you have selected the relevant standard.

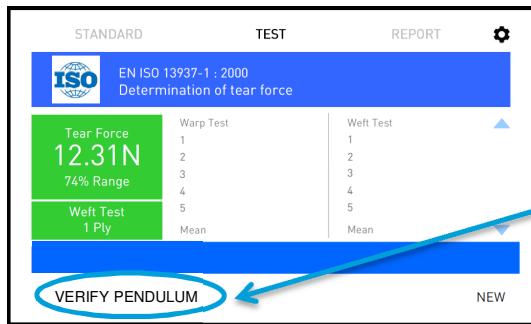

Before testing commences, verify the pendulum that you intend to use by following the 5 steps as shown below.

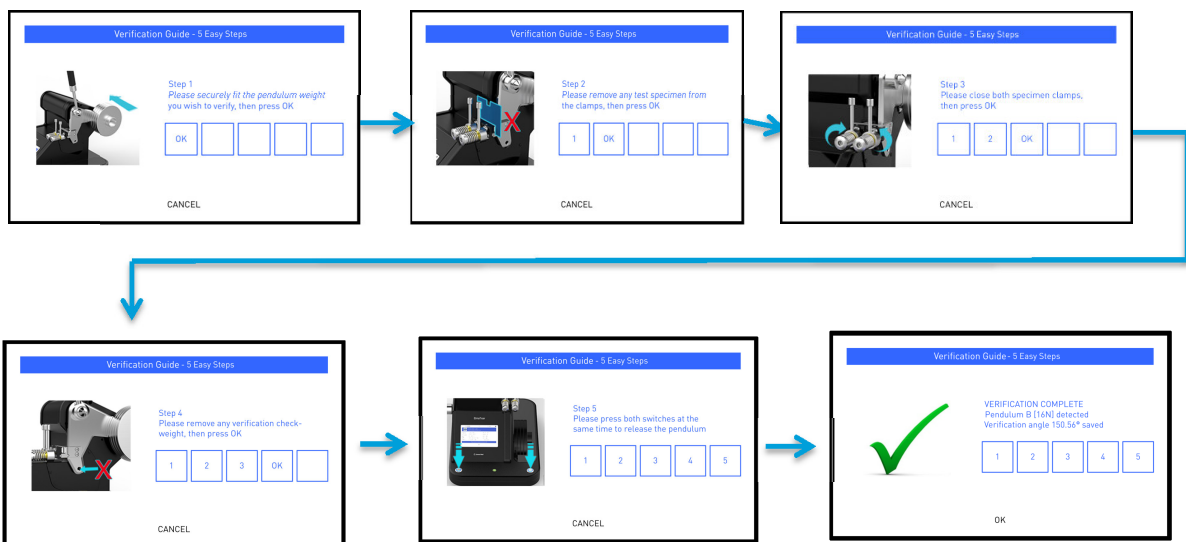

Check Weights

ElmaTear is supplied with a set of six (or seven) check weights, one for each corresponding pendulum: ¼A, ½A, A, B, C and D (and E*).

These enable the operator to confirm that the unit is functioning correctly.

This method provides one check point approximately mid-range of each pendulum.

This method does not replace a calibration performed by a Service & Calibration Engineer.

Do not use check weights when verifying the pendulum (free swing test).

- Check the instrument is level
- Select a standard to measure in Newtons with a single ply
- Close both jaws WITHOUT a specimen
- Fit the pendulum weight of choice
- Verify the pendulum (see pendulum verification)
- Return the arm to test position
- Add corresponding check weight to the position indicated below



Once the check weight is in place:

- 'Notch' the 'specimen' (no specimen)
- Release the pendulum arm by pressing both buttons simultaneously
- Repeat the test 5 times to create a mean
- The mean should fall between the 2 corresponding figures in the table below.

Check Weights - Acceptable Parameters

Check Weight	Target Force (N)	Minimum Reading (N)	Maximum Reading (N)
¼A	1	0.989	1.034
½A	2	1.978	2.068
A	4	3.956	4.135
B	8	7.91	8.27
C	16	15.82	16.54
D	32	31.65	33.08
E*	64	63.3	66.16

* *Optional*

If the reading is unsatisfactory, carry out checks as below, then test the performance of the instrument after adjustments:

- Levelling
- Tightness of the locking nuts
- Tightness of knurled handwheel to prevent the weight from rotating
- Jaws are empty and closed
- Movement of the instrument - if it moves, fix to a bench

If there continues to be a problem, contact James Heal Service & Calibration.

Changing the Jaw Faces

The standard jaw faces are coated with rubber. Do not leave the clamp jaws closed as the faces will stick together.

If the jaws need to be closed for a period of time, insert the metal Jaw Separator (where supplied) or a small piece of paper between the jaws.

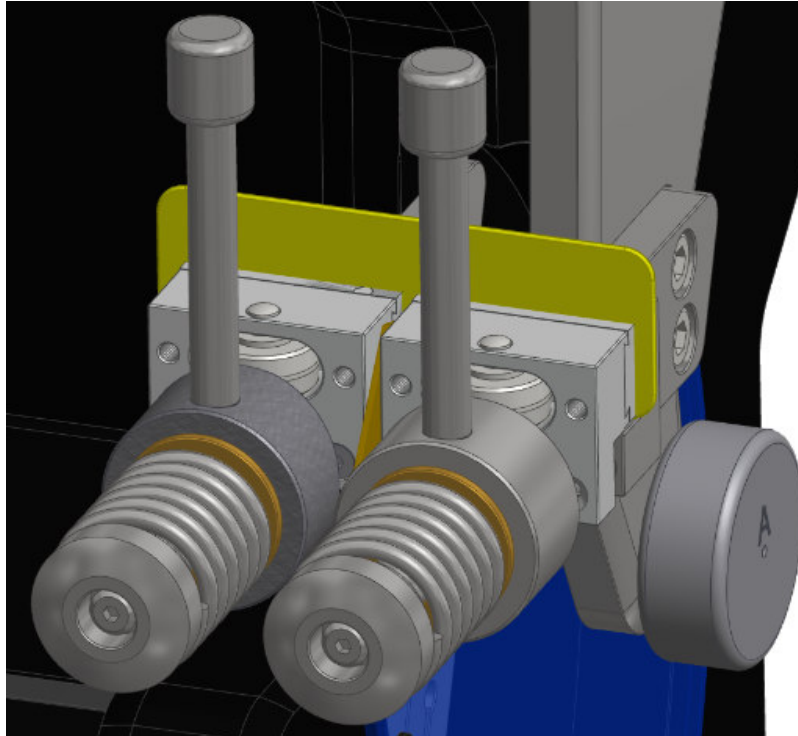

The optional E pendulum kit contains serrated jaw faces which provide additional specimen gripping at high tearing forces.

Each jaw face is held in place by 2 grub screws. Using the hex driver supplied in the kit, loosen the grub screws until the jaw face slides out. Slide the new jaw face into the jaw and retighten the grub screws. Ensure the short edges of the jaw faces are aligned with edges of the jaws to provide the correct jaw separation.

Cutting Blade

Replacing the Blade

When not in use, the blade is safely stored behind a guard.

The blade is specially treated with titanium nitride to prolong its life. The durability of the blade depends on the nature of the material under test and the use of the instrument.

Periodically, the blade will need replacing. Exercise caution when replacing the blade and discard responsibly as **a dull blade is still dangerous.**



Remove any weights from the pendulum. Release the pendulum & hold in the position shown in the picture on the left. Please take care when doing this.

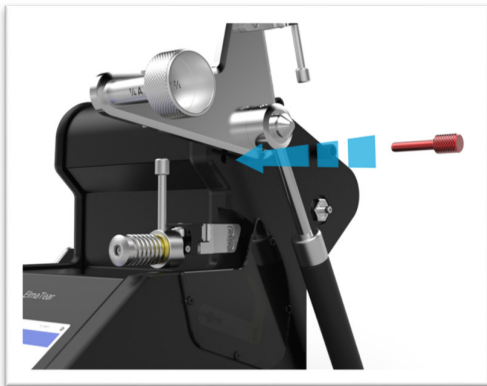

Insert the red safety peg into the hole located underneath the arm.

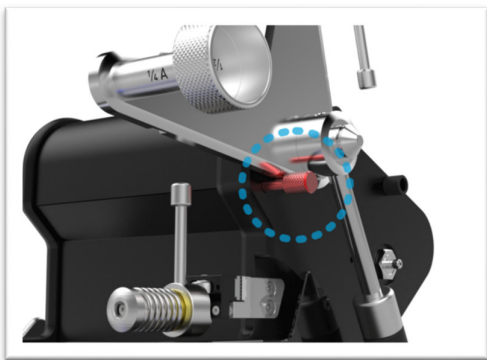

Please ensure the peg is fully inserted.



Raise the blade by using the blade handle on the left hand side of the instrument. Remove the blade by loosening the screws, and replace with a new blade.

When complete, remove the safety peg & lower the pendulum back to the start position. The red safety peg is stored at the rear of the instrument.

Setting the Cut Length

A blade setting tool is provided as a *guide* to the cut length. The nature of the material under test influences the cut length achieved with a given blade setting. When changing materials it is advisable to always check the cut length using a calibrated steel rule.

The blade setting tool is placed and gripped in the fixed jaw.

When the knife blade is set to the correct position, the blade will just clear the setting tool.

Adjustment of the blade is carried out as follows:

Follow the “Replacing/Adjusting the Cutting Blade” procedure to secure the arm and reveal the blade.

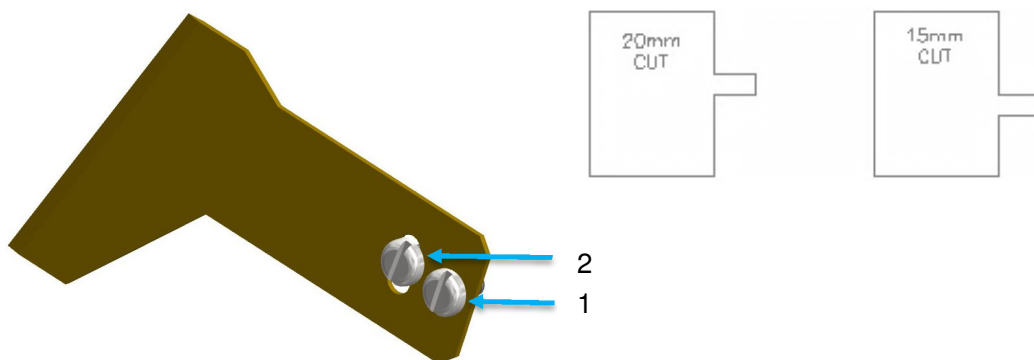

Loosen both screws by turning counter clockwise, sufficient to allow the blade to pivot.

Adjust the blade as required and re-tighten screw no.2 by turning clockwise, sufficient to hold the blade in place. Repeat this procedure until the blade just clears the bottom of the setting tool. Tighten screw no.1.

Testing the Specimen

Set the pendulum arm in the raised starting position to align the jaws. The specimen is held between a pair of jaws, one moveable and the other fixed to the instrument. The moving jaw is attached to a V-shaped pendulum-arm to which the pendulum weights are added.



Place a test specimen centrally in the jaws so that the specimen is set carefully against the bottom of the jaws.

Rotate the handles into a vertical position to clamp the specimen.

Pull the lever on the left side of the instrument forward to notch the specimen.



Please press both buttons at the same time to release the pendulum.

NOTE: The pendulum will swing towards you.

DO NOT LEAN OVER THE INSTRUMENT!

USING THE TOUCHSCREEN

Main Menu

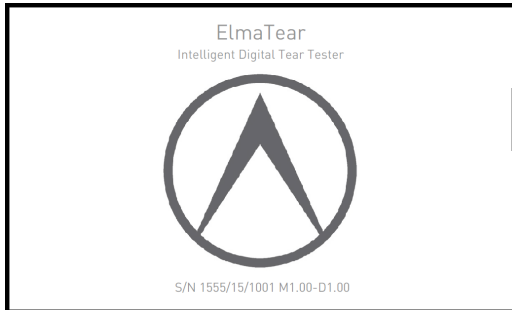

Main start up screen when instrument is powered up.

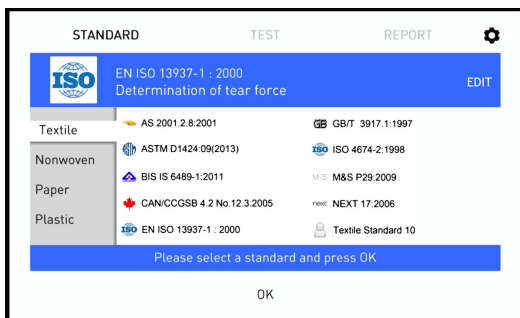

Main menu screen with full list of pre-programmed standards.

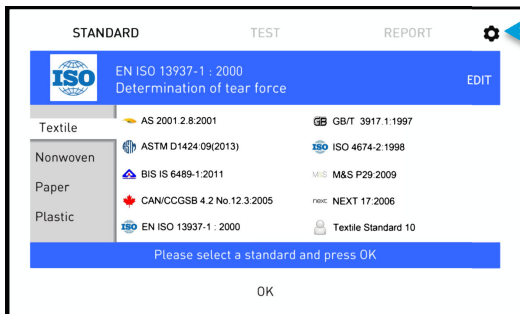

By touching the setting button in the top right hand corner on the main screen, you can edit specific setting such as:

- Date
- Time
- Language
- Sound Volume

Touch the item to edit.

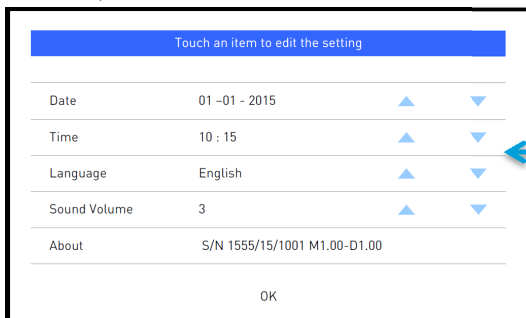

This screen also displays the serial number of the instrument.

Standard Settings



Main menu screen:

To select a standard touch the relevant categories down the left hand side then touch the relevant standard.



To change the test parameters, touch 'EDIT'

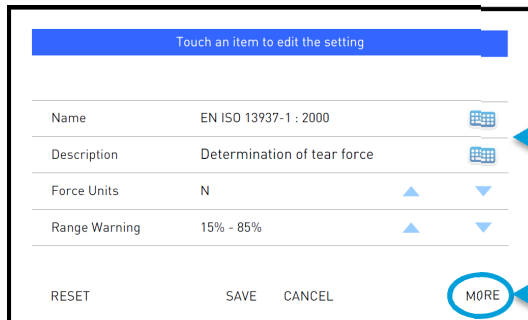

If required, touch an item to edit.

Touch 'MORE' for additional settings.

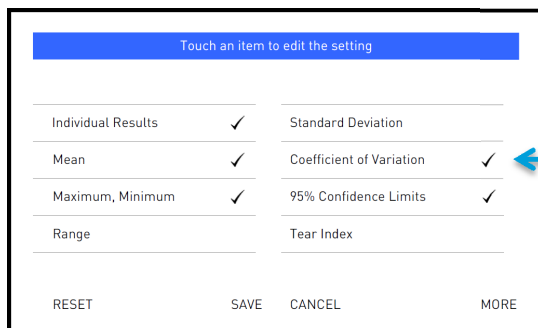

If required, touch an item to select or deselect

These will be displayed on the final report.

Press 'SAVE' when complete.

Test Page

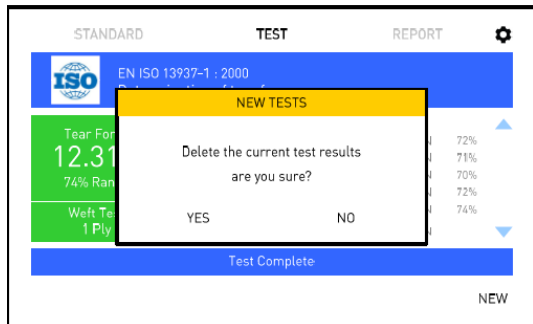
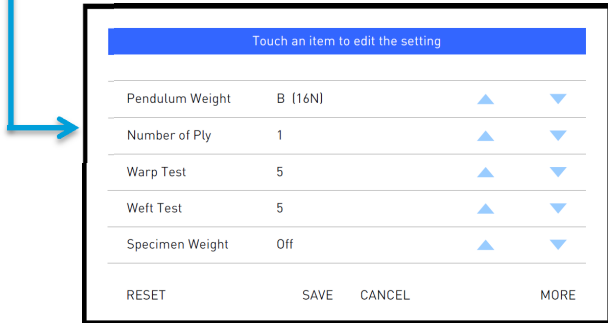
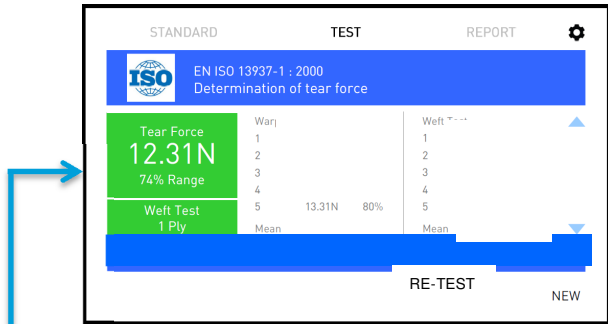

By touching the green area on the screen you can change the test parameters e.g.

- Pendulum weight
- Number of plys
- Number of specimens (warp & weft)
- Specimen weight

By touching 'RE-TEST' you can delete a specimen & retest.

By touching 'NEW' you can carry out a new test.

Please be aware if you have not sent the results to TestWise data logger they will be deleted when a new test starts.

Report Page

STANDARD TEST REPORT

ISO EN ISO 13937-1 : 2000
Determination of tear force

Specimen description here 1
Specimen description here 2
Specimen description here 3

Mean	Warp	Welt
12.86N	12.86N	11.86N
Maximum	13.31N	12.31N
Minimum	12.52N	11.52N
CV%	2.291	2.484
OV%	0.365	0.365

Temperature 20°C
Humidity 65%RH

Ready to send the test report to your PC

SEND

Touch 'Specimen description here...' to enter your own information. There are 3 lines available.

Press the X at the right hand side of the blue bar to delete all text.

Determination of tear force_ X

!	#	£	\$	%	^	&	*	()	
Q	W	E	R	T	Y	U	I	O	P	
A	S	D	F	G	H	J	K	L	:	
Z	X	C	V	B	N	M	<	>	?	
Esc	↑	Space					✕	Enter		

Once this is complete you can then send your results to TestWise on your PC.

TESTWISE FOR ELMATEAR

TestWise for ElmaTear is a software programme developed at James Heal. It allows a test report created on ElmaTear to be send to a PC. The report can then be printed and/or saved in multiple formats.

Hardware Connections

With the power off, connect one end of the USB A to B cable to the USB B connector on the left of [ElmaTear](#) and the other end to a spare USB A port on your PC.

Power up the PC then [ElmaTear](#).

Software Installation

Insert the CD into your DVD/CD-ROM drive. The set-up program will start the installation wizard, which will guide you through the set-up procedure.

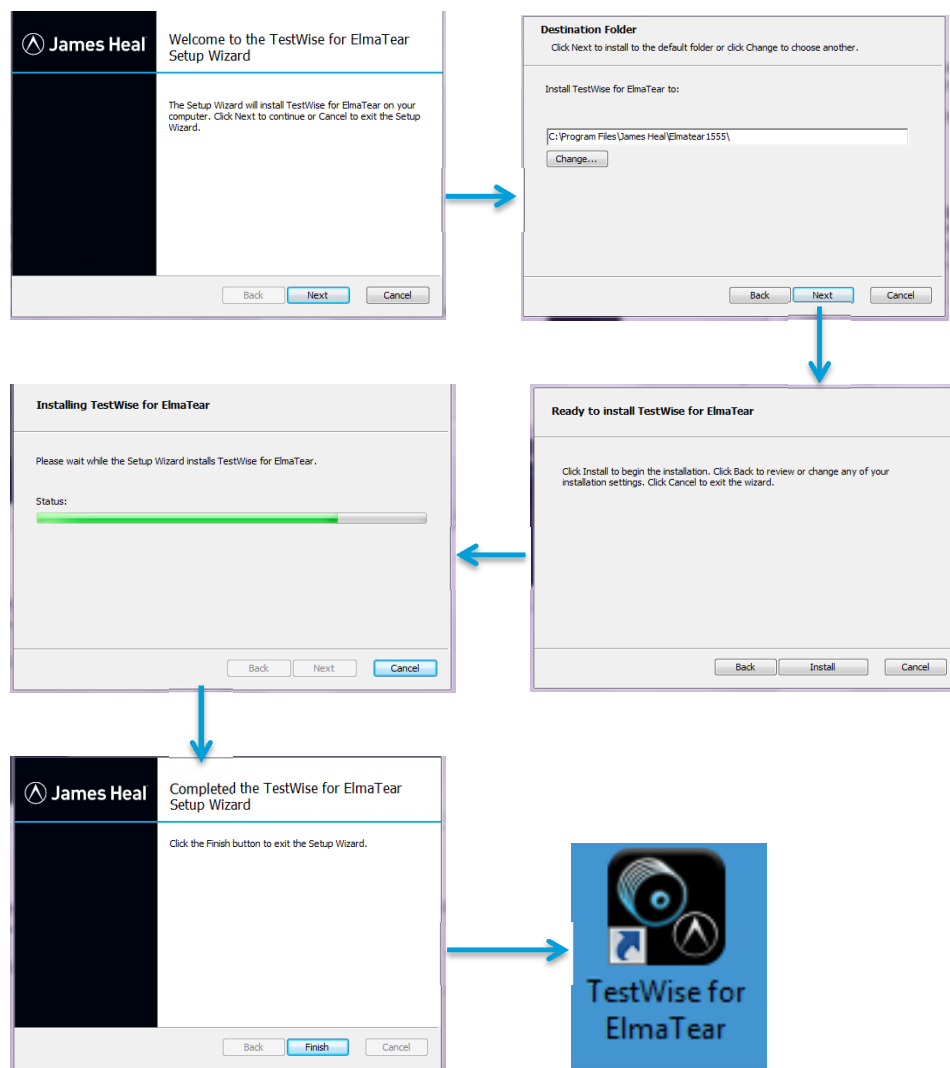

Using TestWise for ElmaTear

After installation, double click on the 'TestWise for ElmaTear' desk top icon to open the data logger programme.

The FTDI driver may need to be installed. Double click the FTDI installer and follow the instructions as indicted by the images below.

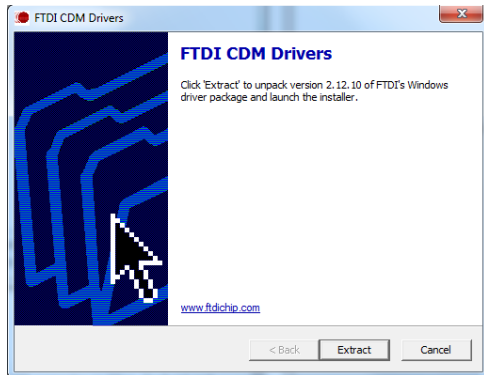

Click on 'Extract' to start the process

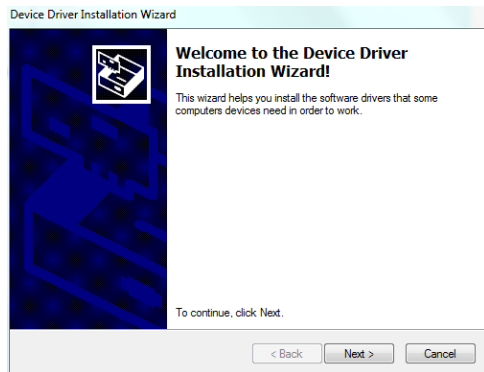

To continue, click Next

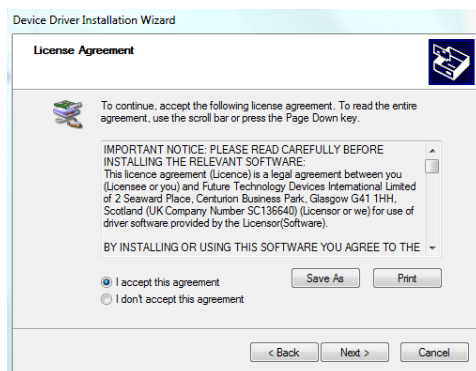

Read and accept the License Agreement

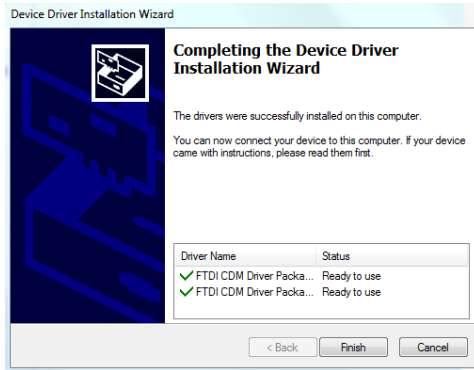

Click finish

Double click on the 'TestWise for ElmaTear' desk top icon to open the data logger programme.



Once a set of tests have been completed on ElmaTear, and the report has been created, the ElmaTear screen displays an option to send the report to the PC - press send.



The report will appear on the PC monitor.



Retrieve the saved reports by selecting **Load Results**, and search for the required document.

Select **Recent** to view recently created reports.

Select **Save Results** to create a document in .etr format (ElmaTear).

Reports can be printed by selecting **Print Results**.

Select **Save PDF** to save the report as a pdf.

Select the **settings** option, to change the language (if available) and to choose whether to include a logo and a graph in the report. The communication port can also be selected here.

CARE AND MAINTENANCE

Keep the instrument free from dust and debris.

As the blade is safely stored behind a guard when not in use, debris may become trapped behind this. Periodically, remove the guard and **very carefully** clean the area.

Wipe clean with a lint free cloth dampened with water.

DO NOT use window cleaners, household cleaners, compressed air, aerosol sprays, solvents, ammonia, abrasives, or cleaners containing hydrogen peroxide to clean ElmaTear.

Touch Screen Care

This is designed for fingertip use only.

Do not use pens or other pointed implements - this will lead to damage.

The touch screen will need to be cleaned periodically. To do this, use a soft, slightly damp, lint-free cloth. Avoid getting moisture in openings.

James Heal Service & Calibration

James Heal Service & Calibration is an ISO 17025 based comprehensive, worldwide support programme.

Our instruments come with an 18 months warranty period.

Our aim is to provide precisely the services you need to maintain and protect the value of your investment.

In all communications please quote the serial number of your instrument and the software version number, for example: 1555/15/1001 and V1.00.

James Heal Service & Calibration contact details:

E-mail support@james-heal.co.uk

Telephone +44 (0) 1422 366355

Fax +44 (0) 1422 352440

TECHNICAL DATA

Standard Pendulum Weights

- 2N (¼ A)
- 4N (½ A)
- 8N (A)
- 16N (B)
- 32N (C)
- 64N (D)

Optional Pendulum Weight 128N (E)

Standards 40 freely programmable standards:
10 x Textile, 10 x Nonwoven, 10 x Paper, 10 x Plastic

Pre-Programmed Standards :

Textile :

- AS 2001.2.8:2001
- ASTM D 1424:09(2013)
- BIS IS 6489-1:2011
- CAN/CGSB 4.2 No.12.3:2005
- EN ISO 13937-1:2000
- GB/T 3917.1:1997
- ISO 4674-2:1998
- M&S P 29:2009
- NEXT 17:2006
- JIS L 1096 D

Paper :

- AS 1301.400s:1998(2013)
- GB/T 455:2002
- ISO 1974:2012
- NZS 1301.400s:1998(2013)
- PAPTAC D9:1993
- TAPPI T 414 om-12

Plastic :

- ASTM D 1922:2009
- BIS IS 13360-5-23:1996
- GB/T 16578.2-2009
- ISO 6383-2:2004
- JIS K 7128-2:1998

Statistics

- Individual Results
- Mean, Maximum
- Minimum, Range
- Standard Deviation
- Co-efficient of Variation
- 95% Confidence Limits
- Tear Index

Range Warning Off, 15%-85%, 20%-60%, 20%-75%, 20%-80%

Calibration

- Built-in calibration guide
- Automatic pendulum detection and calibration angle
- Verification check-weights for each pendulum

Encoder Digital non-contact, zero friction encoder

Measurement Units N, cN, mN, kgf, gf, lbf, ozf

Number of Tests	Up to 100 tests in each direction Combined X and Y direction tests on one report
Number of Ply	1 to 16
Maximum Specimen Thickness	5 mm
Cutting Blade	Titanium nitride coated
Cut Length	15 to 20 mm
Weight	50 kg
Dimensions	620 (L) x 365 (W) x 635 (H) mm
Power	85 to 264 VAC, 50/60Hz, 60W
User Interface	7" Capacitive Colour TFT touchscreen
PC Interface PC Software	USB port TestWise for ElmaTear PC Application
Safety	Interlocked 2-handed pendulum release Automatic pendulum arrest after initial swing

EU Conformity

- Machinery Directive 2006/42/EC
- Low Voltage Directive (LVD) 2014/35/EU
- Electromagnetic Compatibility (EMC) Directive 2014/30/EU
- Waste Electrical and Electronic Equipment recycling (WEEE) Directive 2012/19/EU
- Restriction of Hazardous Substances (RoHS) Directive 2011/65/EU

REVISION HISTORY

See front cover for publication number, e.g., 290-1555-1\$A

Revision	Date	Originator	Details Of Revision
A	18/01/2016	LS & CB	New version for ElmaTear 1555
B	19/01/16	CB	p14 transit screw p21 jaw separator
C	6.6.16	CB	Added JIS L 1096 D 'NEW' removed EU conformity
D	5/7/2018	PG	Updated Spares tables pages 11, 12 and 13, and Front Cover